

LEGITIMACY IN GROUP DECISION MAKING

Daniel L. Chen (IAST, Toulouse)

Moti Michaeli (U. of Haifa, Israel)

Daniel Spiro (Uppsala U, Sweden)

February 2020

Introduction

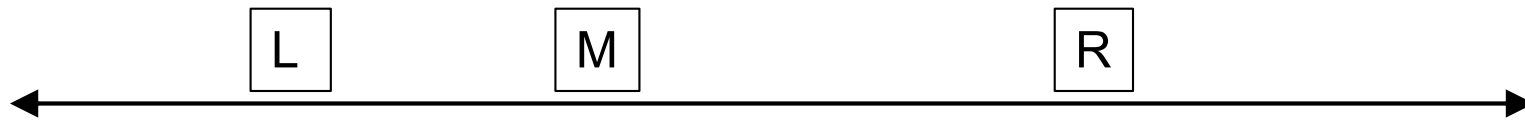

- Most theories of politics/voting assume: an option “A” needs a certain vote share (50%) to win over “B”.
- When many alternatives A, B, C... → The median gets his/her preferred option.
- Median does not need to please anyone else, abstention not a problem.

Introduction

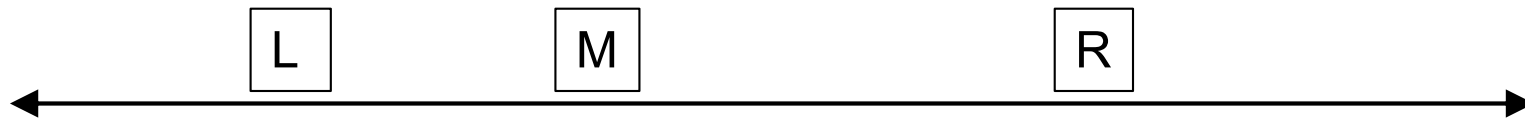

- But in many real situations, getting endorsement of other voters is important. (Patty & Penn 2013; Epstein et al., 2011; Martin & Stevenson 2001)
- Increases legitimacy of decision
 - ▣ by giving it more weight
 - ▣ and since those other voters will not criticize it
- Especially in **situations with few voters**:
- Politics (and conflict): many coalitions are larger than strictly needed.
- Committees.
- Courts: when several judges, “norm” of unanimity.

Research question



- How does the quest for legitimacy affect decisions (voting outcomes)?
- (When) does the median-voter theorem hold?
- What is the “Bargaining power” of different agents?

- To be answered theoretically...
- ...and tested empirically.

Model: players

- Three agents: L, M, R .
- Each has an ideology $\in \mathbb{R}$.
- $L \leq M \leq R$



Model: payoffs

- Agents bargain about a policy $v \in \mathbb{R}$.
- Payoff for agent t :

$$U(v; t; n) = \begin{cases} (c - |v - t|)\lambda^{n-2} & \text{if } n \geq 2 \\ -K & \text{if } n < 2 \end{cases}$$

$c > 0$ constant, $\lambda > 1$ constant,

n number of agents signing

K constant, large so that majority is always better

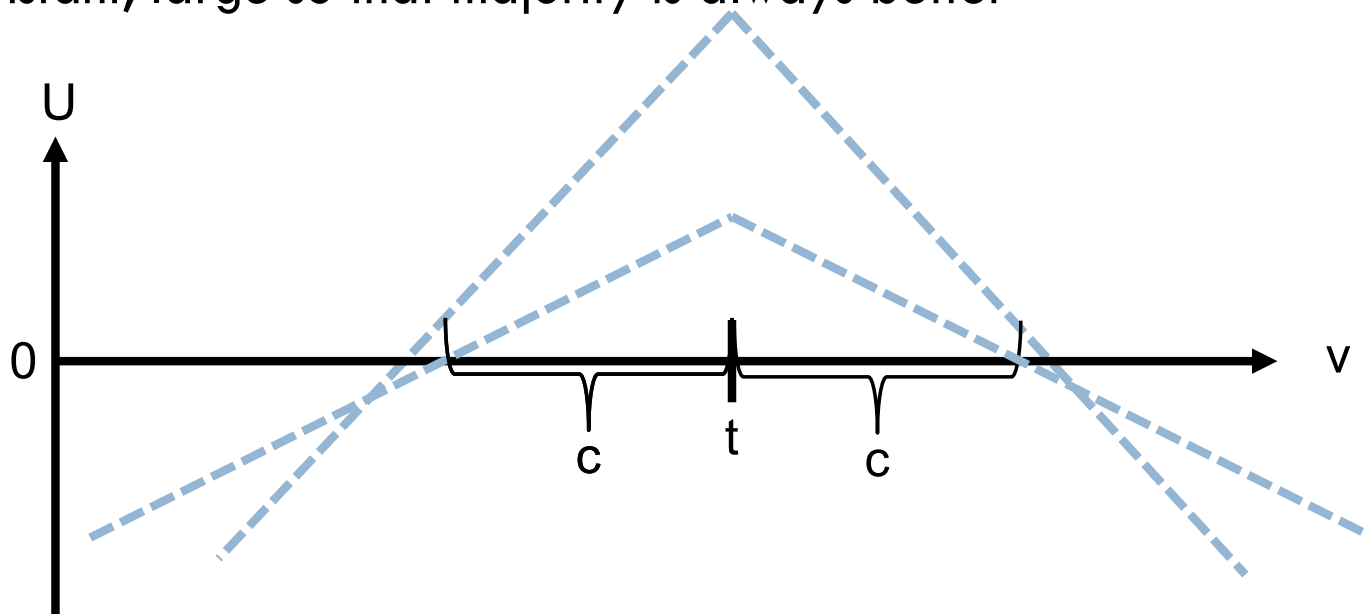

Model: timing



1. Agents vote (Condorcet) about which single agent will get to propose v .
2. The winner proposes v .
3. The remaining two decide whether to sign v .

Main result

Proposition:

(i) $v = L + c$ iff
 $c \leq M - L < (2 - 1/\lambda)c$ and
 $M - L < 2c - (R - M)$.

(ii) $v = R - c$ iff
 $c \leq R - M < (2 - 1/\lambda)c$ and
 $R - M < 2c - (M - L)$.

(iii) $v = M$ if $M - L < c$
and $R - M < c$.

(iv) $v = M$ otherwise

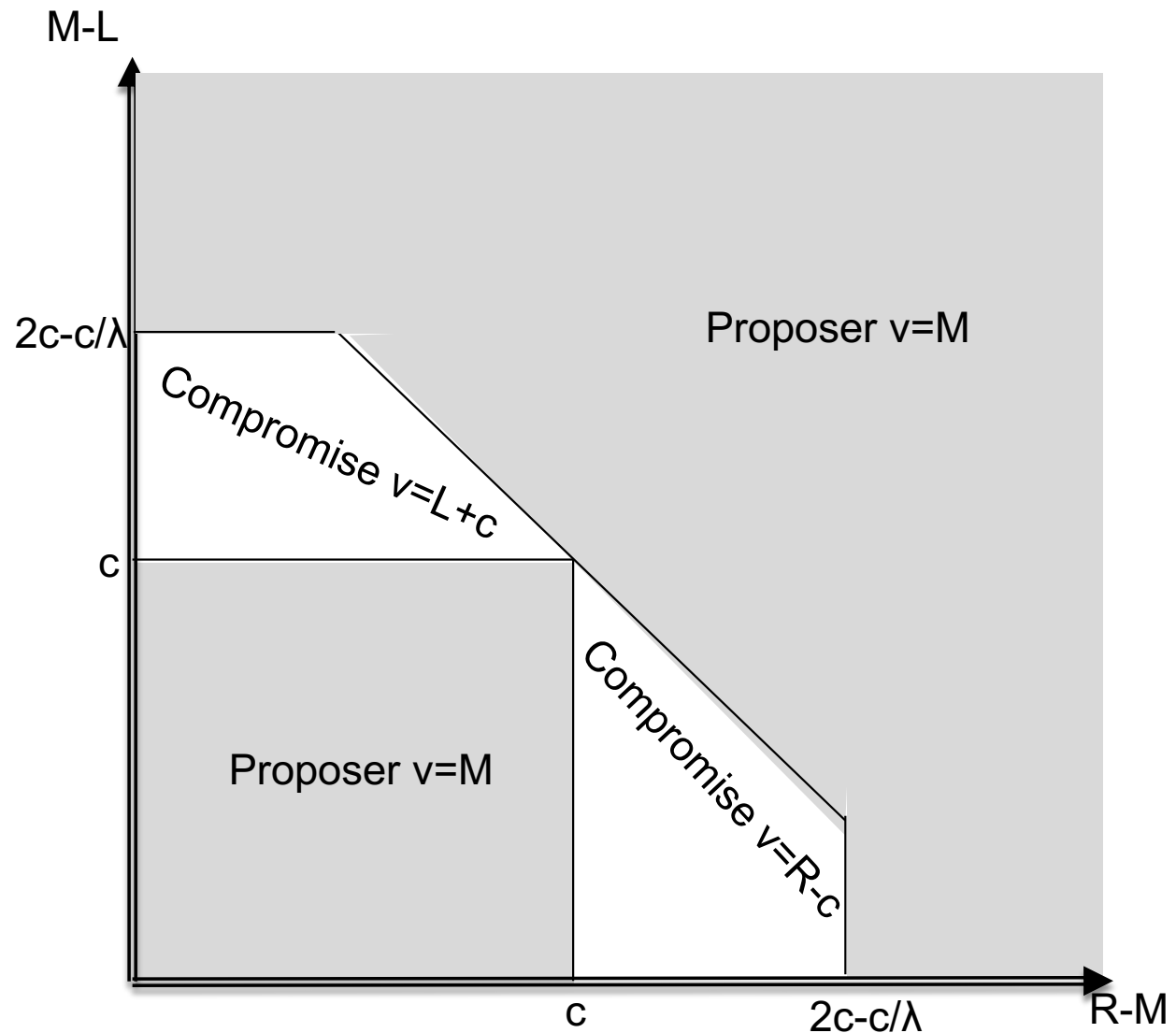

Main result

Roughly:

The median-voter theorem holds when either:

- whole group is **cohesive** (both L and R are close to M)
- whole group is **distant** (both are far from M)
- group is **half cohesive half distant** (one is close, the other far from M)

If one agent is at **intermediate distance** and **one agent is close**, median-voter theorem does not hold.

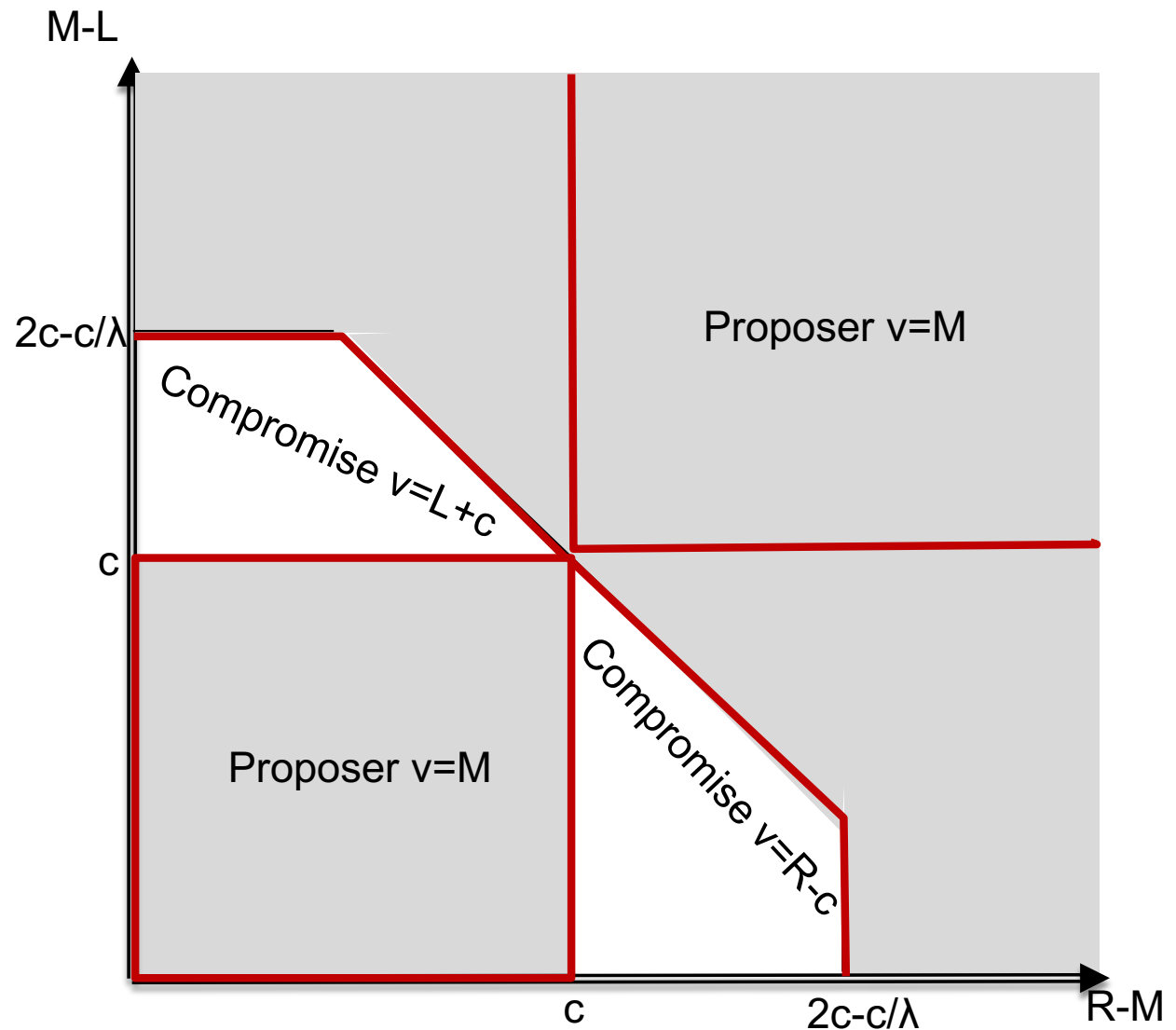

Result: No sabotage

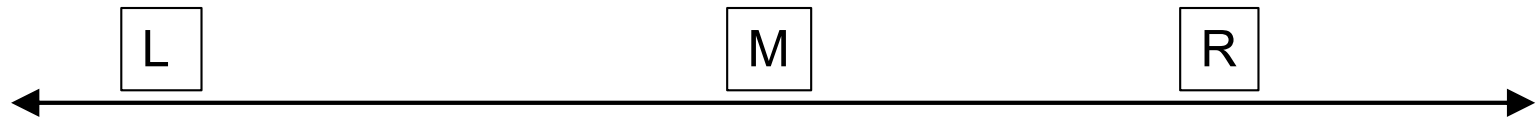

- Would L vote for R to ensure few signatures on bad v ?
- **No:**
- Could only happen if R signs M's v .
- But then M would sign R's v which is even worse for L.

- Median wins first-stage voting, gets to propose.

Bargaining power

- R will sign iff v closer than c .

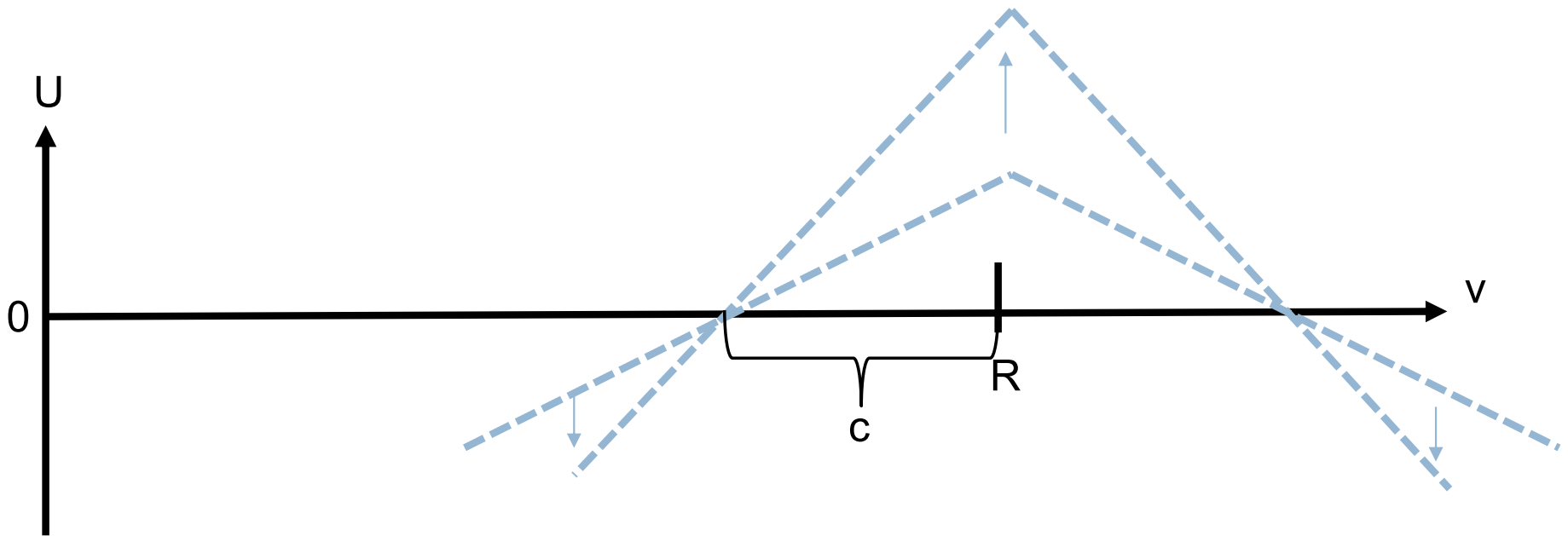

Bargaining power

- M willing to propose v at max distance $(1 - 1/\lambda)c < c$.

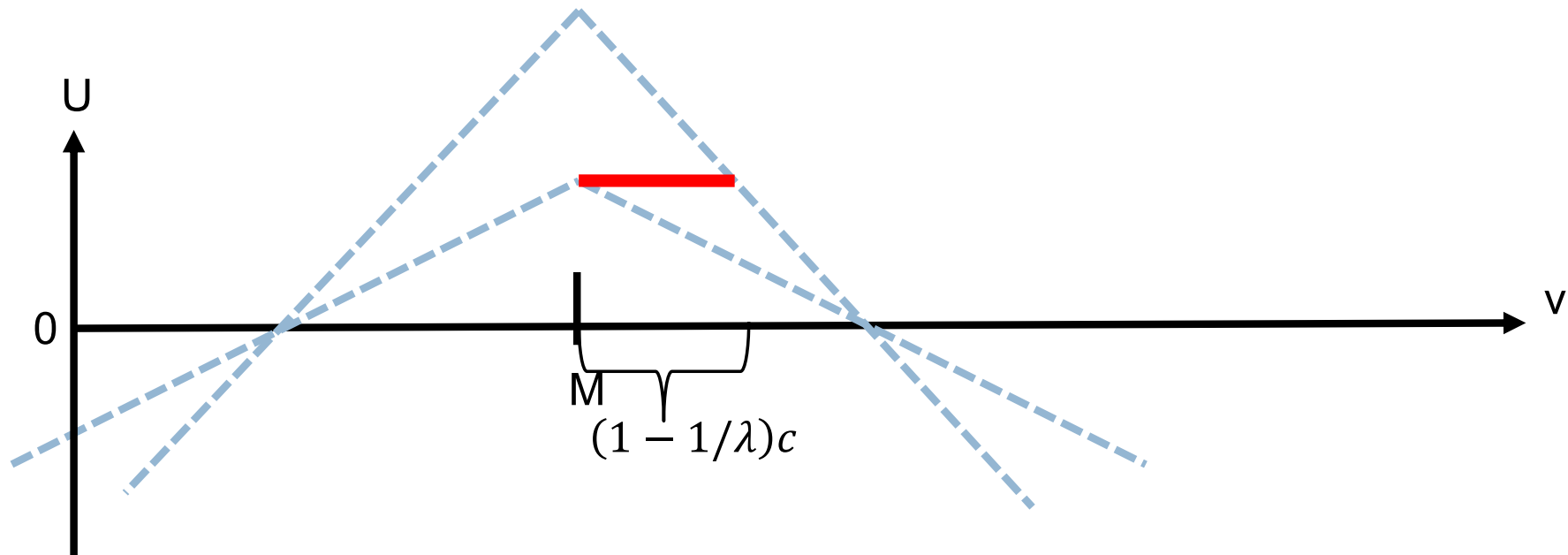

M has more bargaining power

- Willing to "move" less than R or L.
- Sometimes *is able* to move even less/not at all.
- L may be willing to sign more right than M willing to propose.
- **Prediction 1: M has strongest impact on v .**

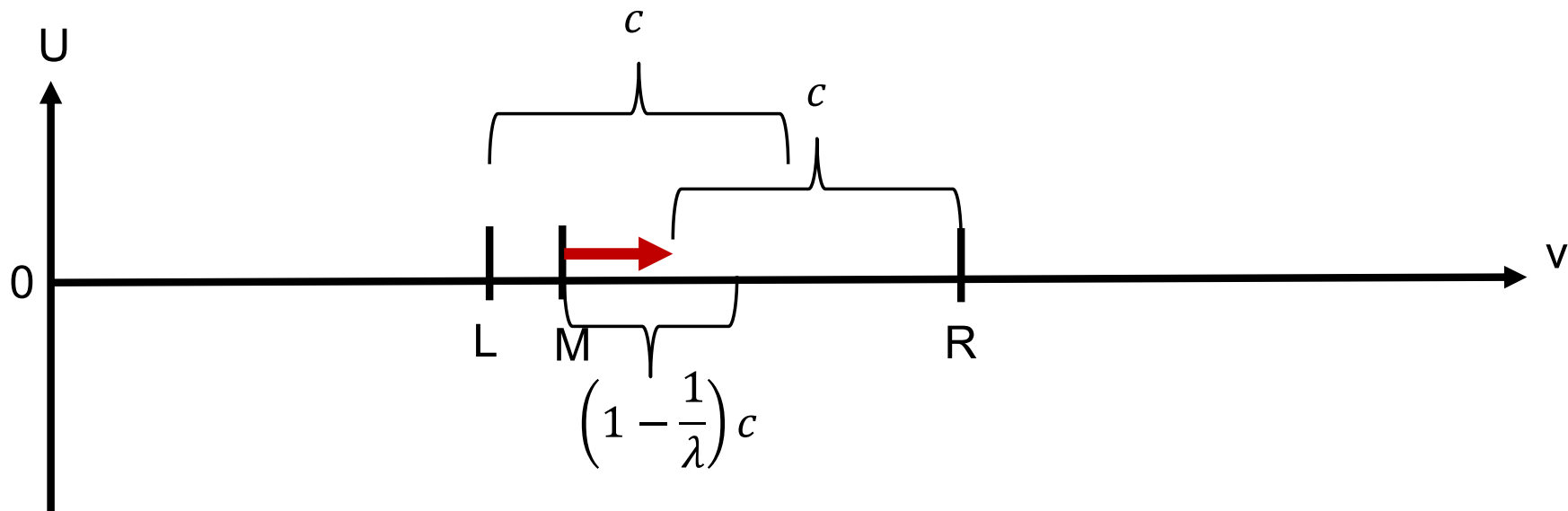

Cohesive groups

- When both L and R are close to M, they sign $v=M$.
- **Median voter theorem holds in cohesive groups.**

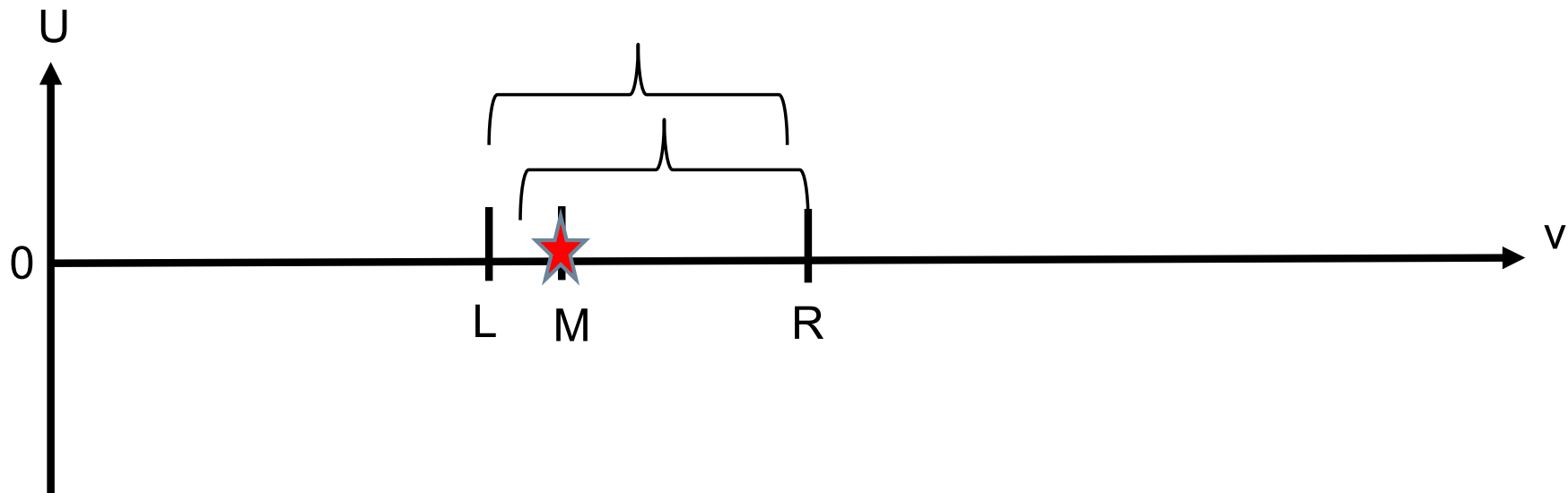

Distant groups

- When both L and R are very far from M, no common ground.
- **Median voter theorem holds in distant groups.**
(One other agent signs to avoid -K)

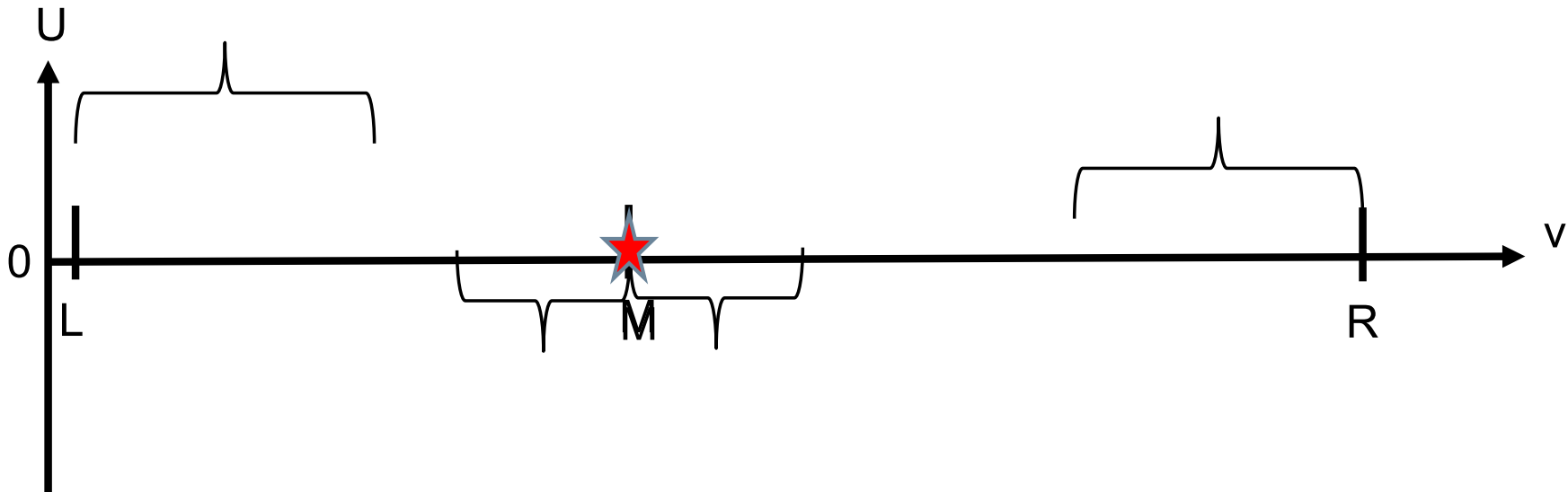

Mixed group: cohesive + distant

- When one is very close to and the other very far from M :
- Close signs $v=M$. Far no common ground.
- **Median voter theorem holds in mixed groups.**

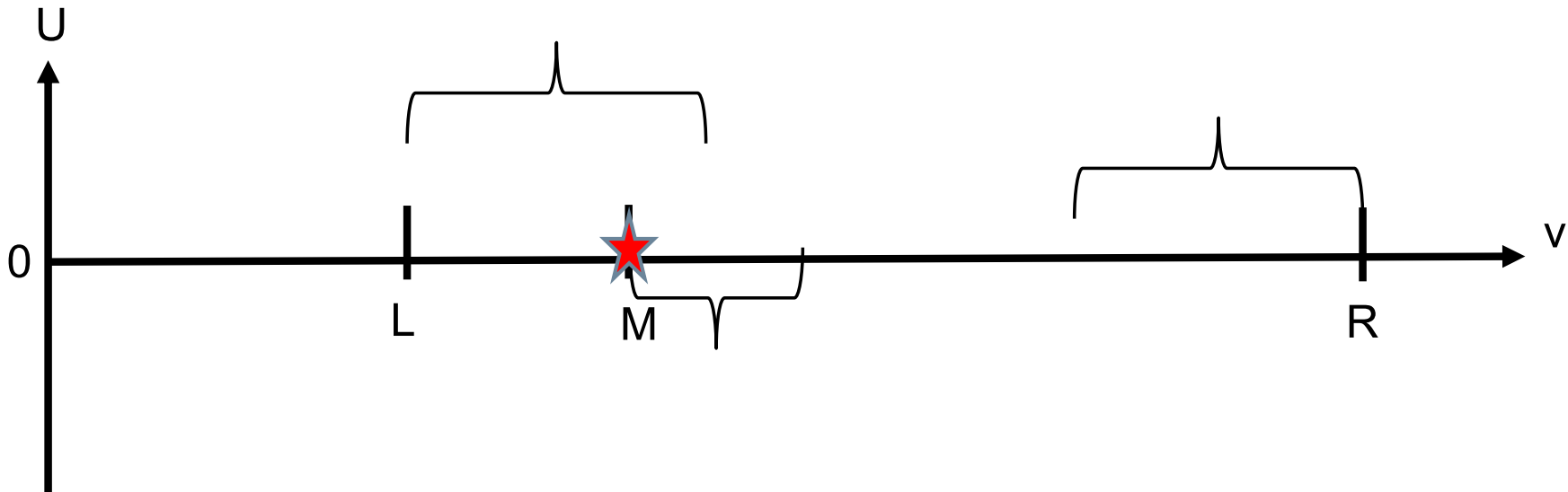

Intermediate cohesion

- Suppose L is somewhat far from M.
- R at intermediate distance \rightarrow common ground if M compromises
- **Median voter theorem does *not* hold if one is at intermediate distance and the other is close.**

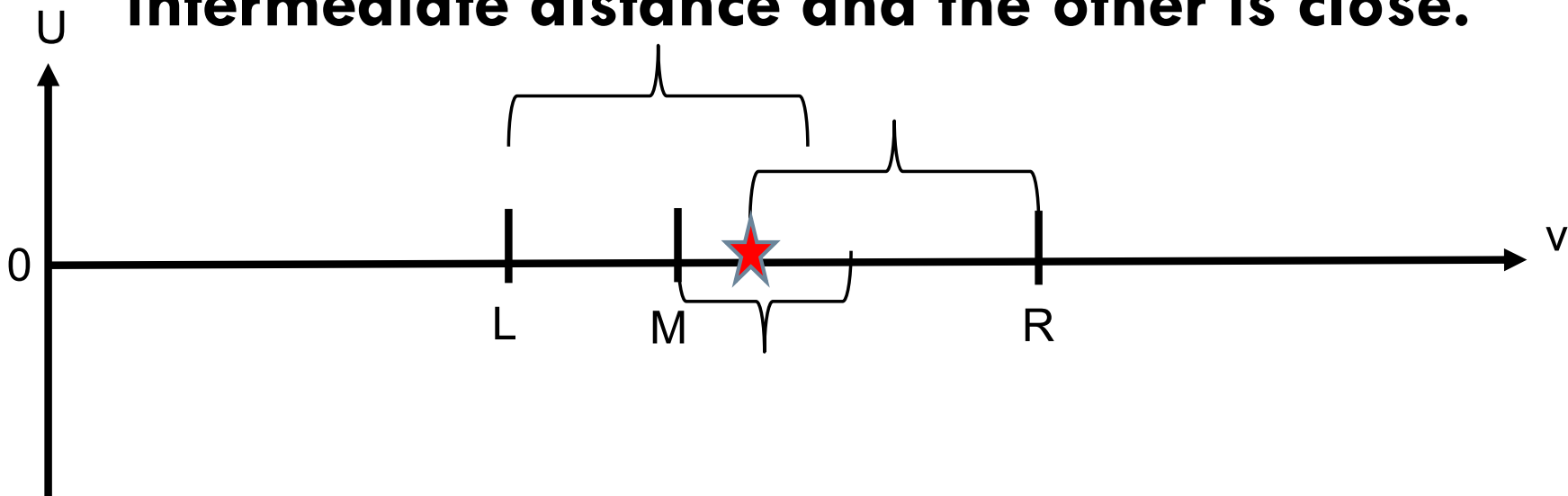

Main result

Roughly:

The median-voter theorem holds when either:

- whole group is **cohesive** (both L and R are close to M)
- whole group is **distant** (both are far from M)
- group is **half cohesive half distant** (one is close, the other far from M)

If one agent is at **intermediate distance** and **one agent is close**, median-voter theorem does not hold.

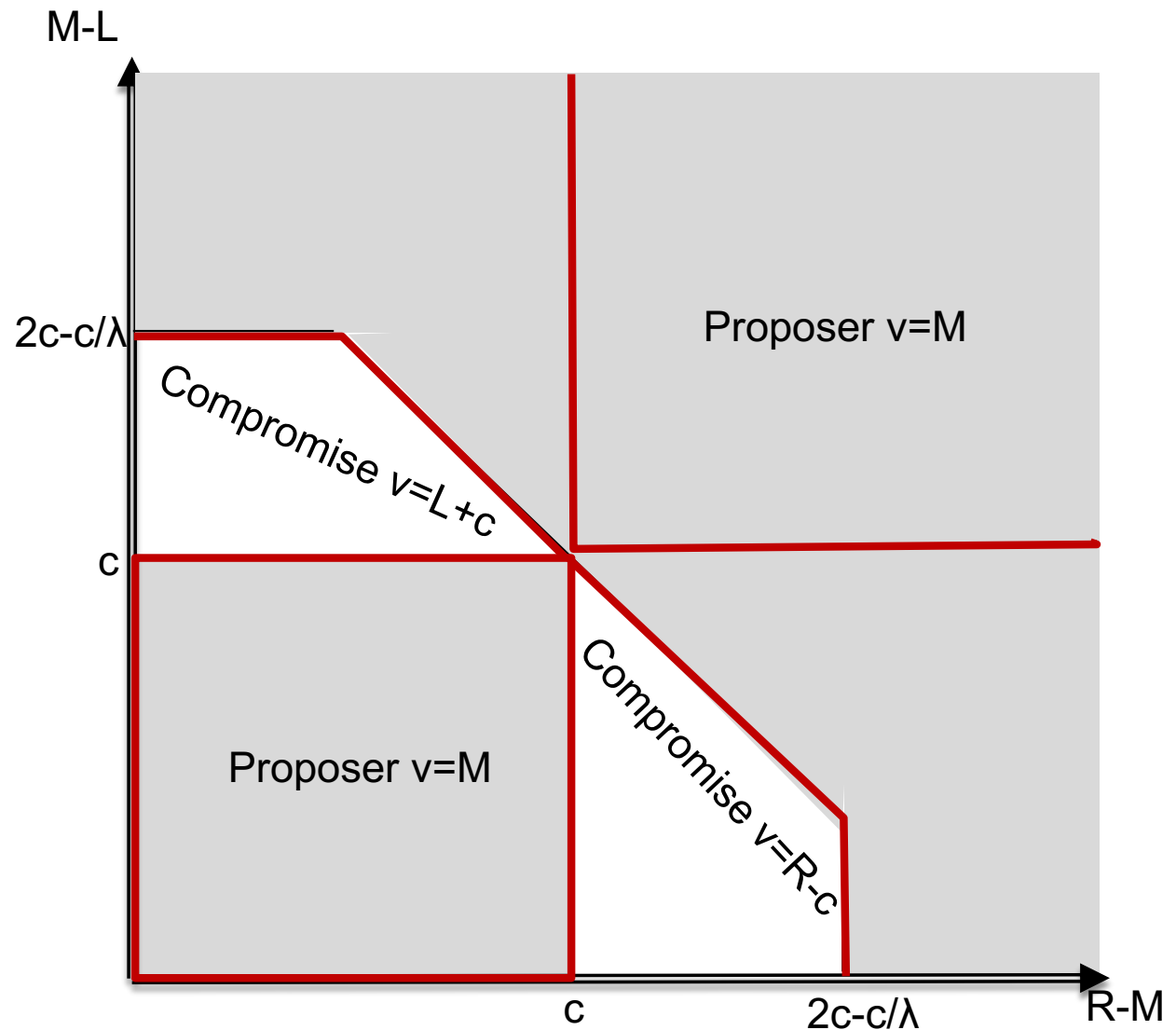

What if L or R proposes?

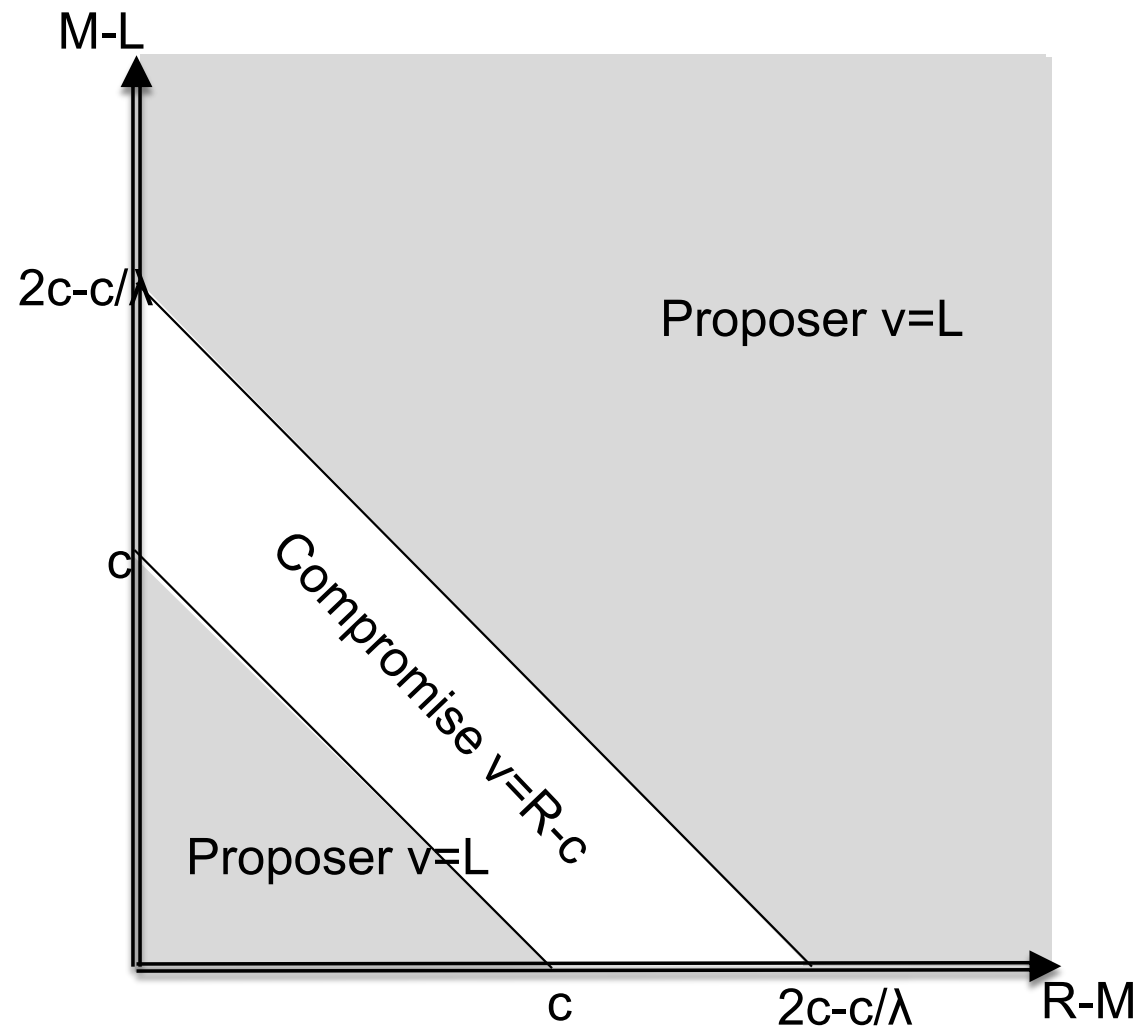

Comparative statics/empirical prediction

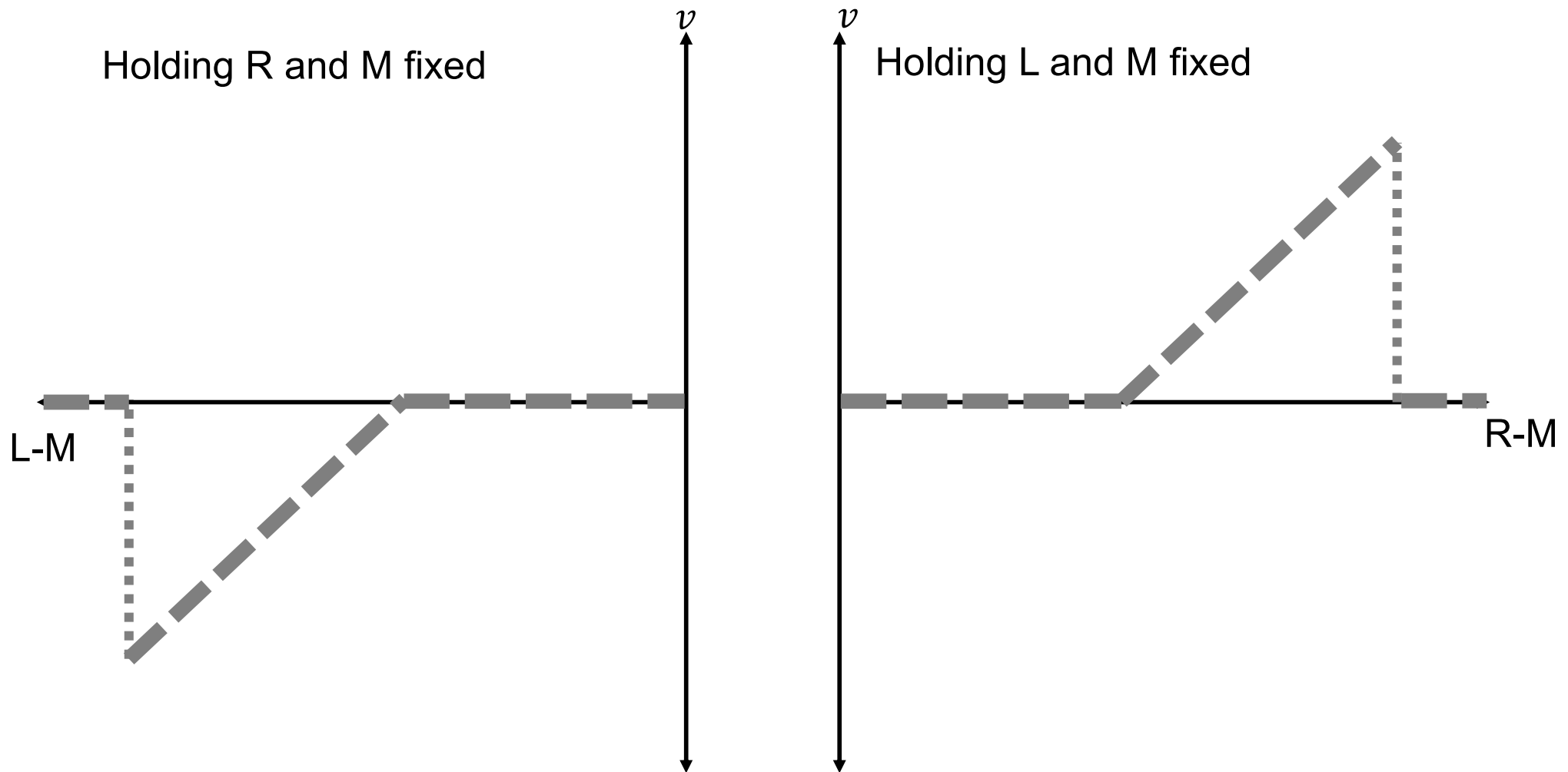

Empirical setting: US Circuit Courts

- Courts of appeals for cases with important principles, e.g.:
 - Interpretation of law.
 - Constitutional issues regarding federal law.
 - Cases that are likely to set precedent.
 - Ideologically contentious issues.
- 98% of decisions are final.
- One step below Supreme Court.

US Circuit Courts: Ideologically salient

Federal appeals court rules against Trump, refuses to reinstate travel ban



Mark Abadi

Feb. 9, 2017, 6:25 PM 35,432



FACEBOOK



LINKEDIN



TWITTER



EMAIL



PRINT

- **The Best Tom Hanks Movies Ever**
(PrettyFamous — By Graphiq)
- **Best Flashlight Ever is Selling Like...**
(Gladiator Flashlights)
- **End Your Nightly Snoring Nightmar...**
(My Snoring Solution)
- **This amazing new technology allo...**
(Flare Audio)

Sponsored Links

A federal appeals court unanimously ruled against President Donald Trump on Thursday, refusing to reinstate his travel ban.

The ruling, issued by a three-judge panel on the San Francisco-based 9th Circuit Court of Appeals, means refugees and citizens of the seven majority-Muslim countries affected by the ban can continue entering the US as the ban makes its way through the court system.



President Donald Trump. Drew Angerer/Getty Images

Empirical setting and data

- US president appoints and senate approves judge
 - President's and home-state senators' ideology (voting pattern) proxy for judge's ideology.
 - ▣ A continuous ideology score developed by Giles et al. (2001).
 - ▣ Judges have life tenure.
- For each case:
 - ▣ 3 **randomly assigned** judges
 - ▣ make decision and **write an opinion – a motivation, often ideological.**
 - ▣ A judge may dissent against (=not sign) the opinion.
- Many cases → many different ideological constellations.

Empirical setting and data

- U.S. Courts of Appeals Database Project and Openjurist
- All judges' ideology scores:
 - ▣ min -0.8 (liberal)
 - ▣ max 0.8 (conservative)
- Random sample of $\sim 5\%$ of cases 1925-2007.
 - ▣ $\sim 20\,000$ cases
- Judge constellation of all cases.
- Ideology of court opinions:
 - ▣ -1 (liberal)
 - ▣ 0 (neutral)
 - ▣ +1 (conservative)

Ideology is salient 1

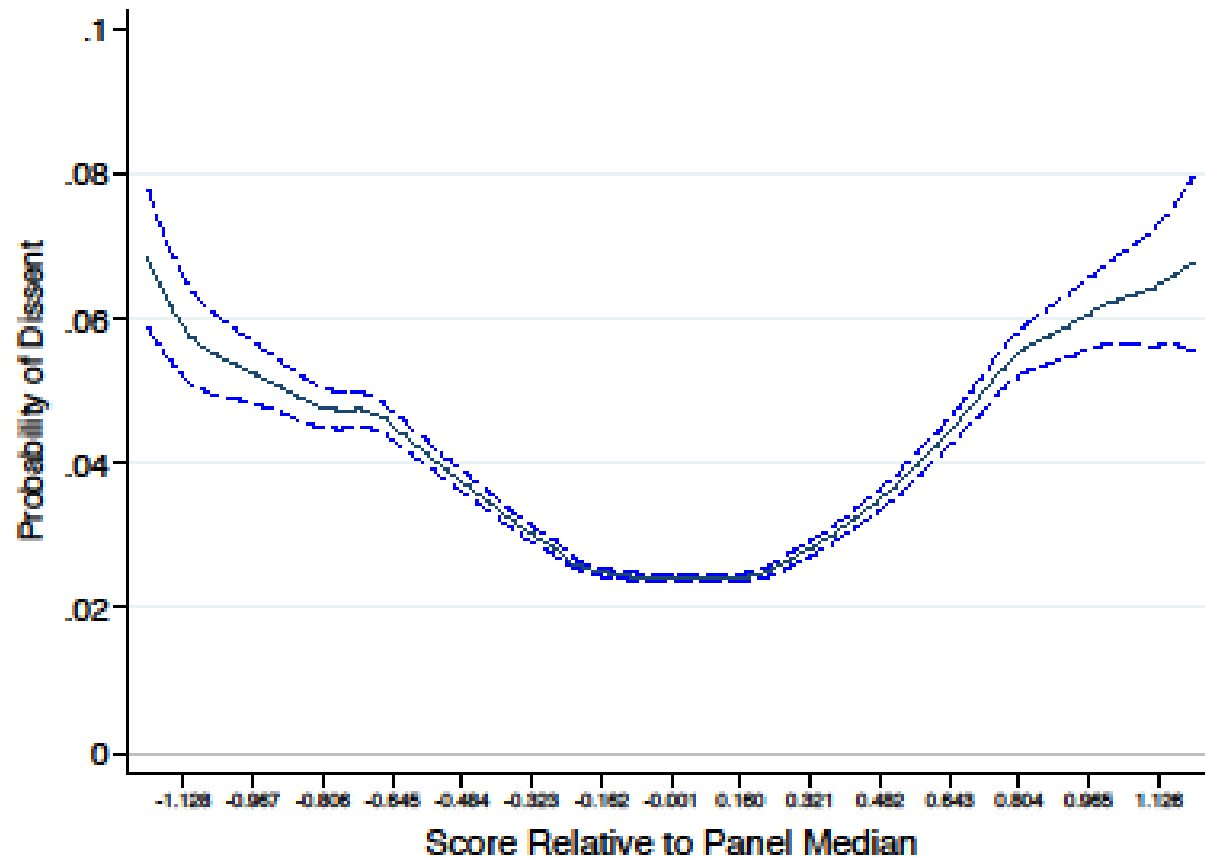

Robustness: Judge FE, circuit FE, year FE.

Ideology is salient 2

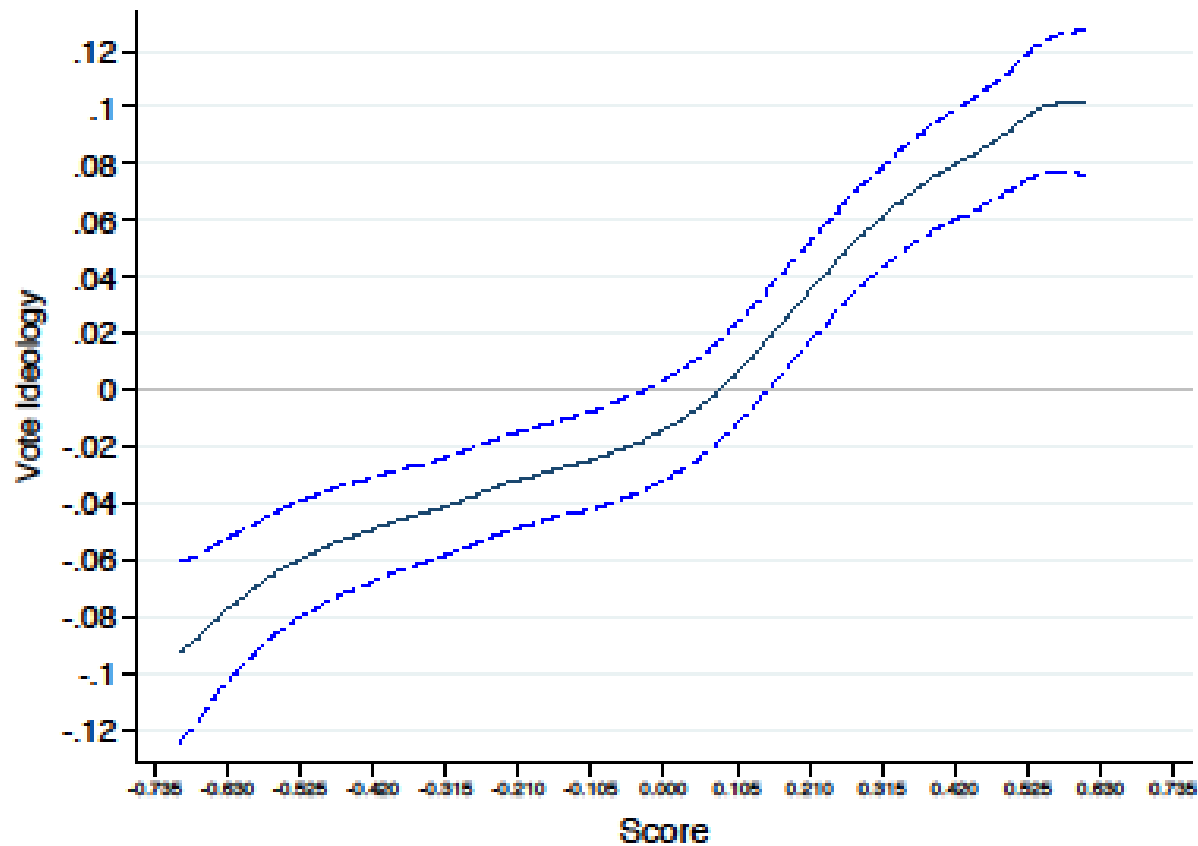

Prediction 1: Median particularly influential

For each panel (=case) and judges in the panel:

$$\text{Majority opinion's score} = b_0 + b_1 \text{ Judge's score} + b_2 \text{ Judge's score} * [\text{judge is median}] + b_3 1 * [\text{judge is median}]$$

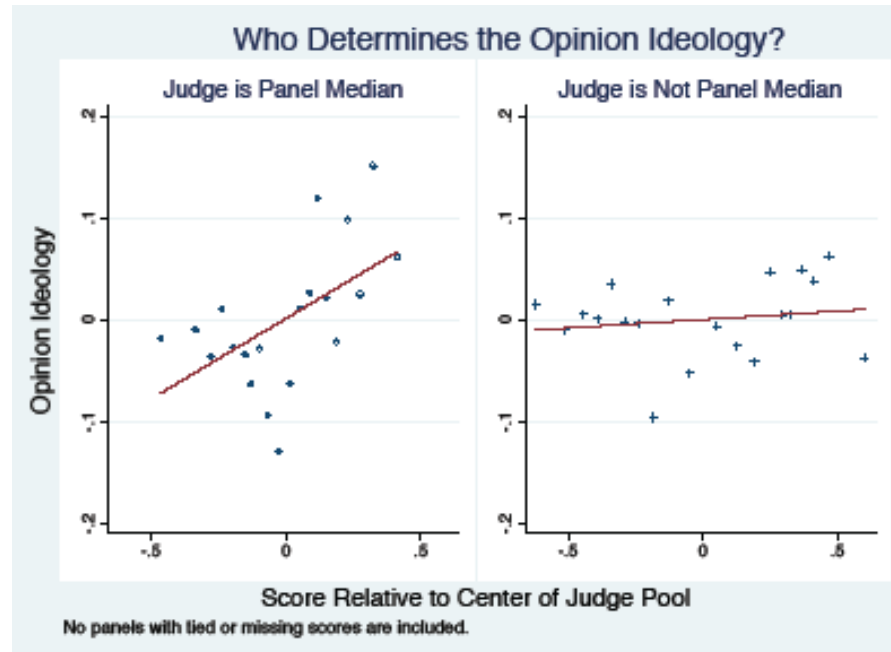

Robustness: Raw score, adding left/right judge score, opinion over career control for circuit.

Result: Either Median influences alone or ~3 times more than others.

Prediction 2: moving from median

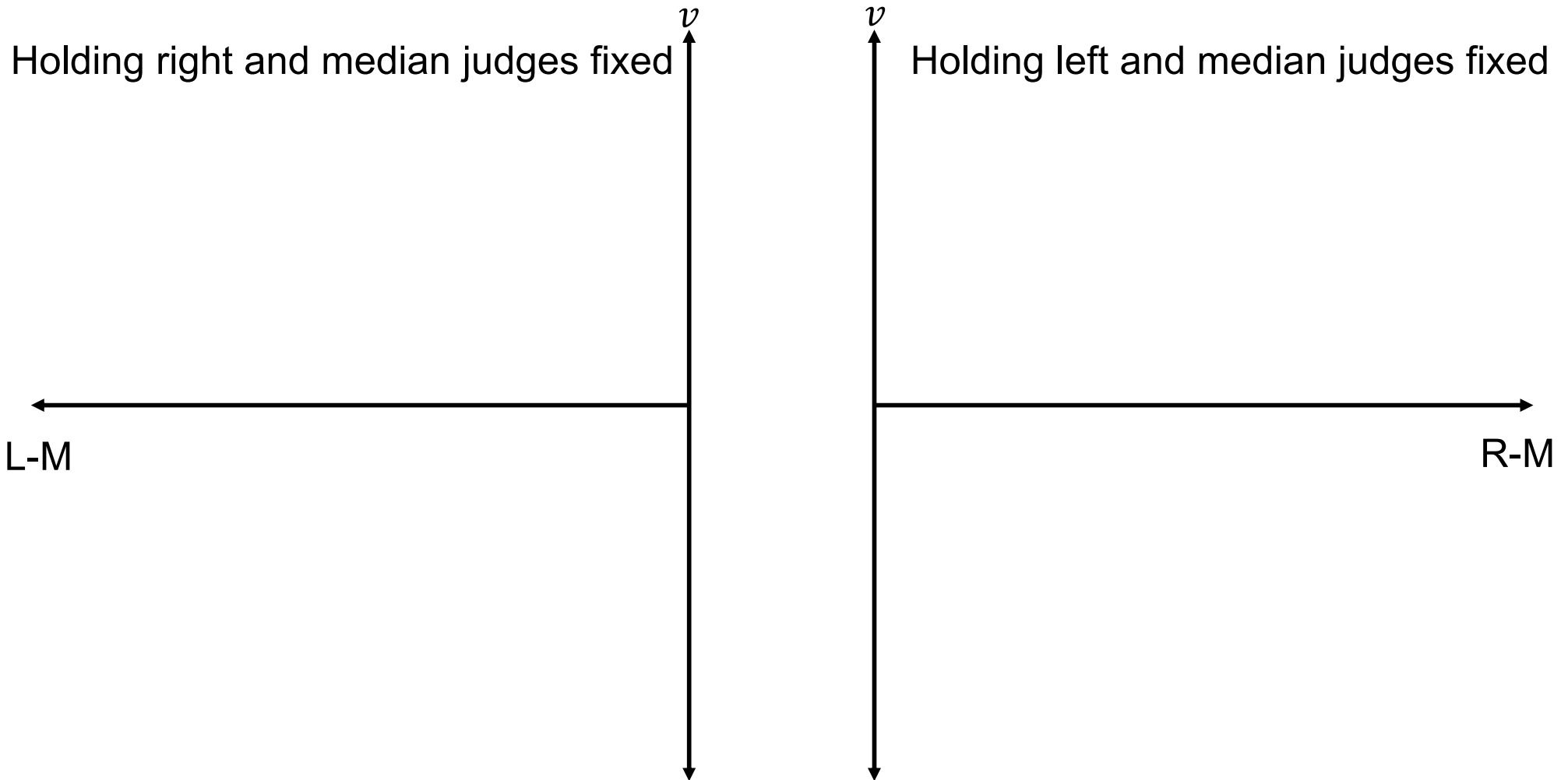

Prediction 2: moving from median

Narrow range of judges

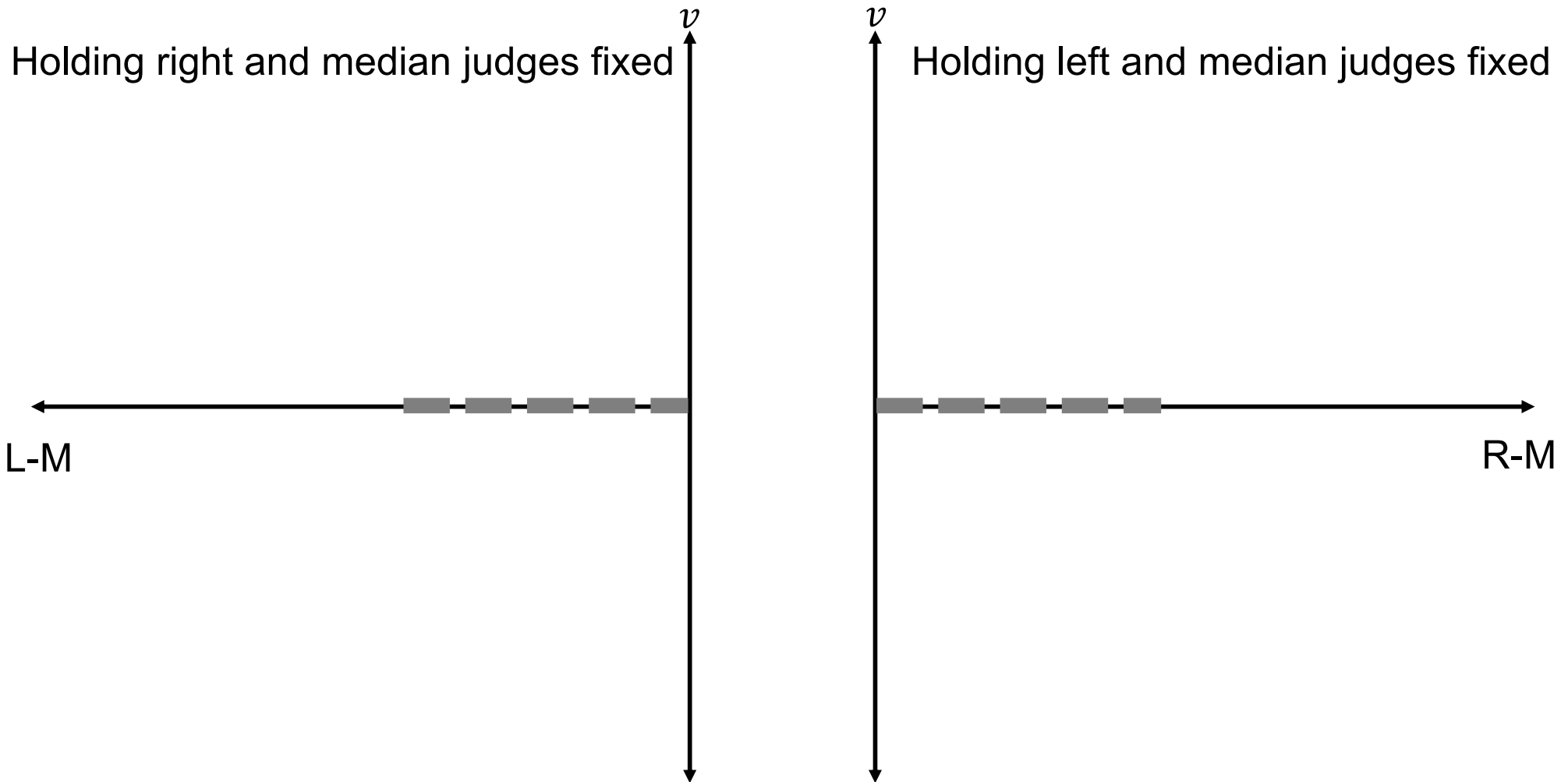

Prediction 2: moving from median

Intermediate range of judges

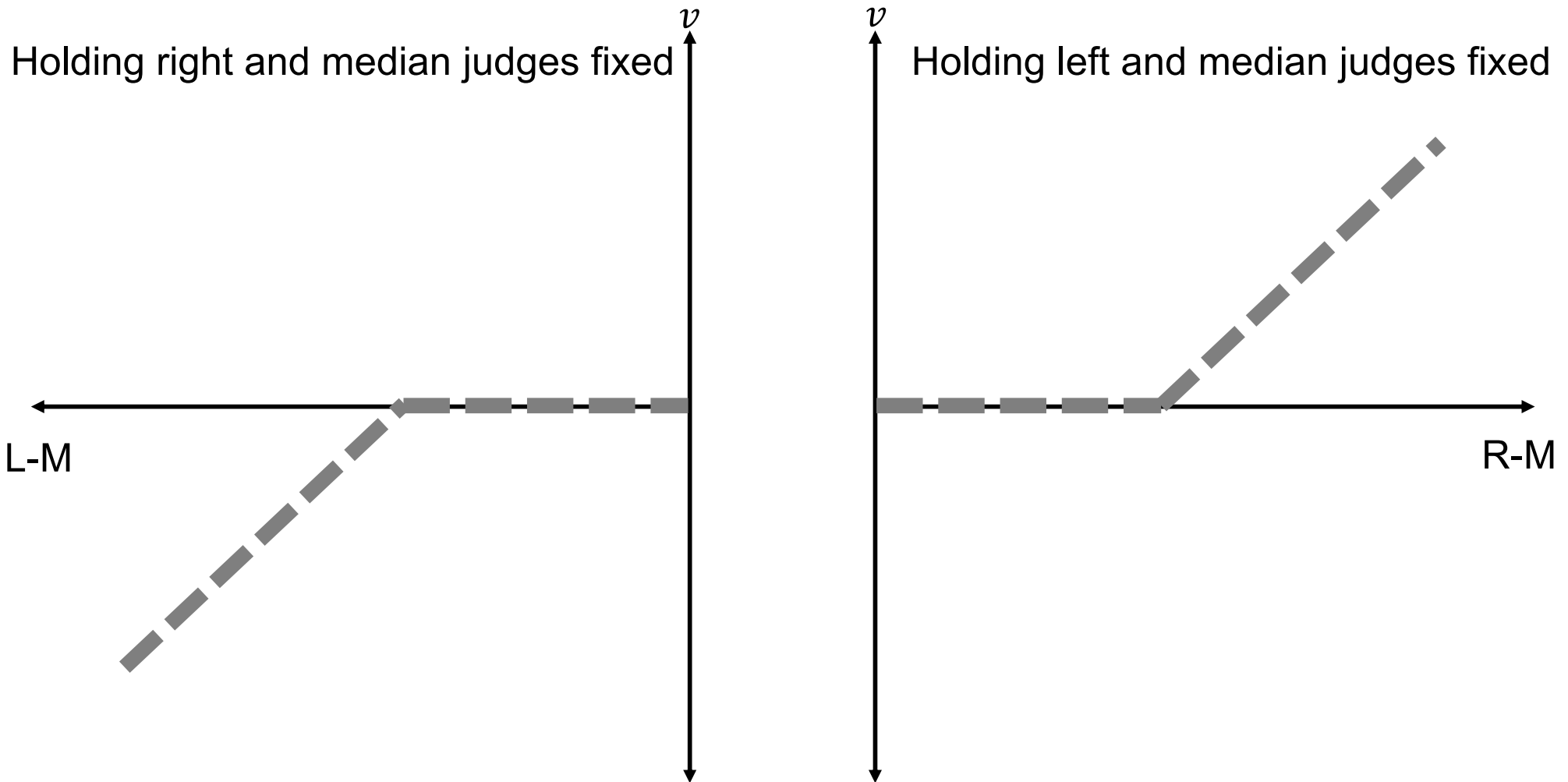

Prediction 2: moving from median

Broad range of judges

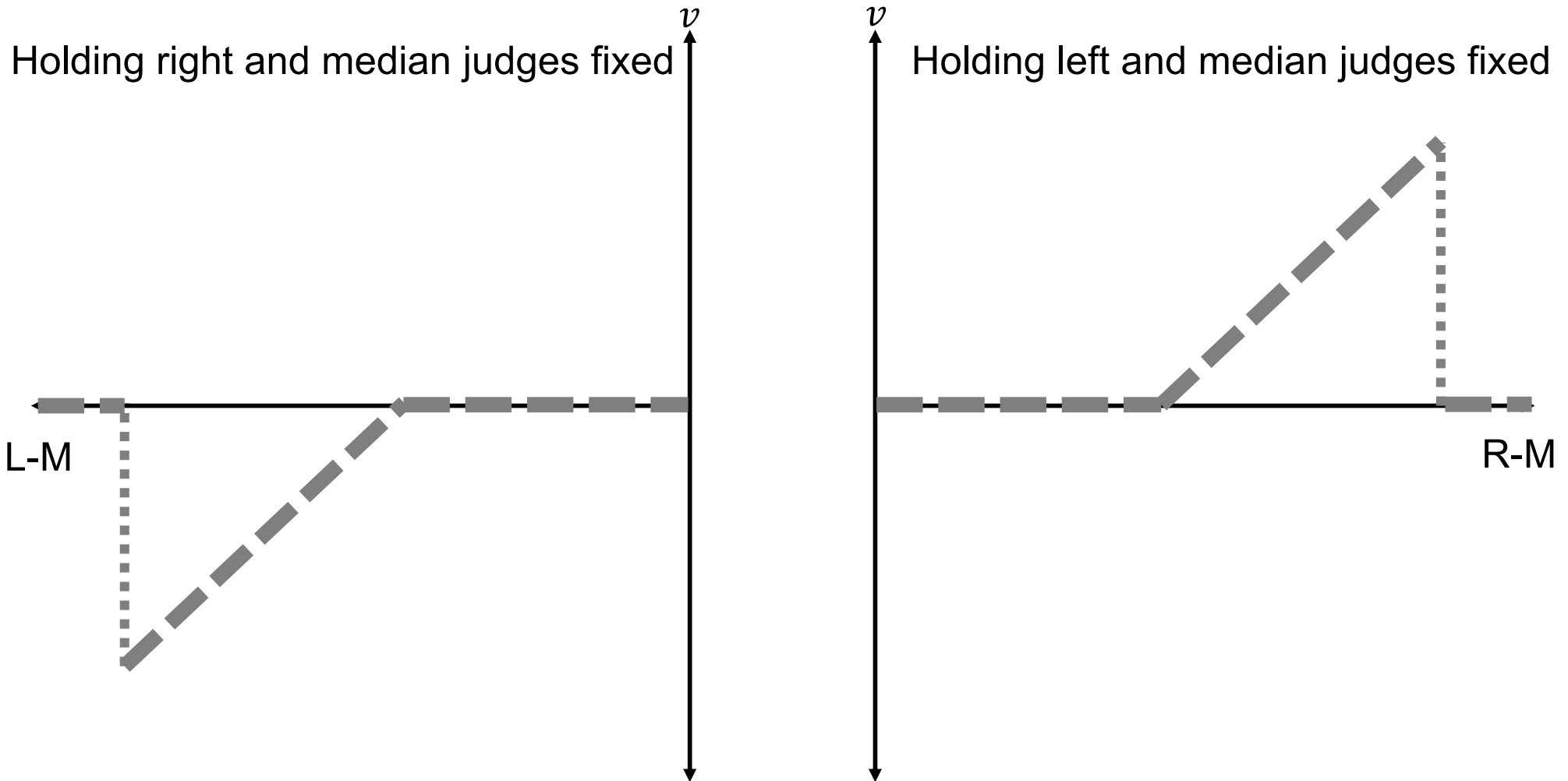

Prediction 2: moving from median

Local polynomial regression controlling:

- Median and Leftist (or Rightist) ideology
- Circuit*Year FE

Leftist

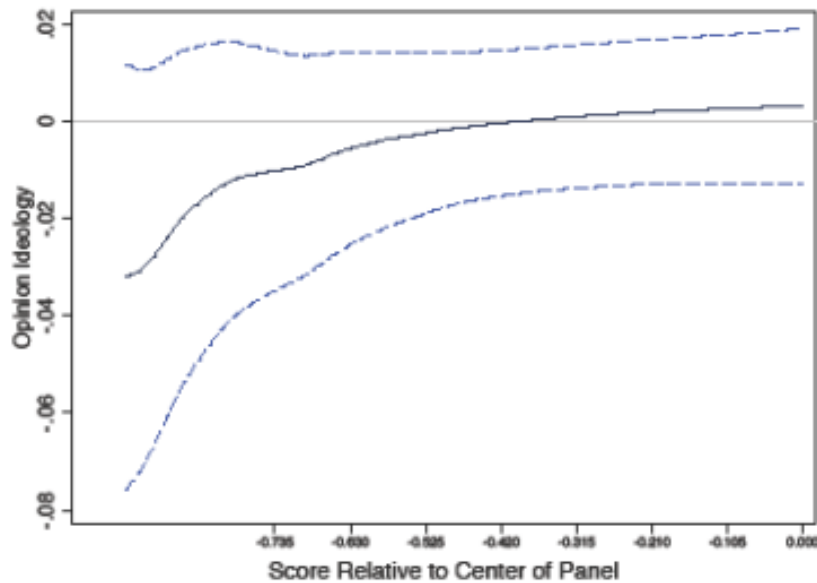

Rightist

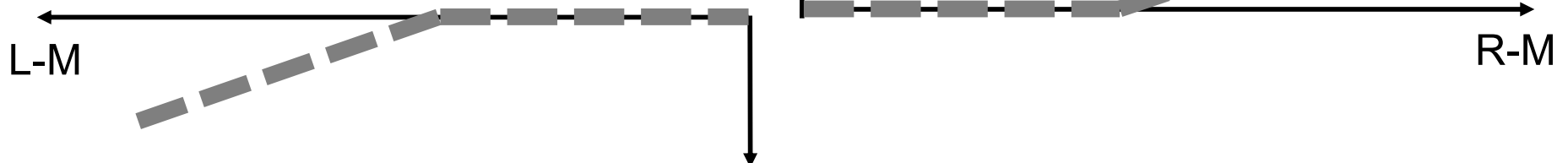
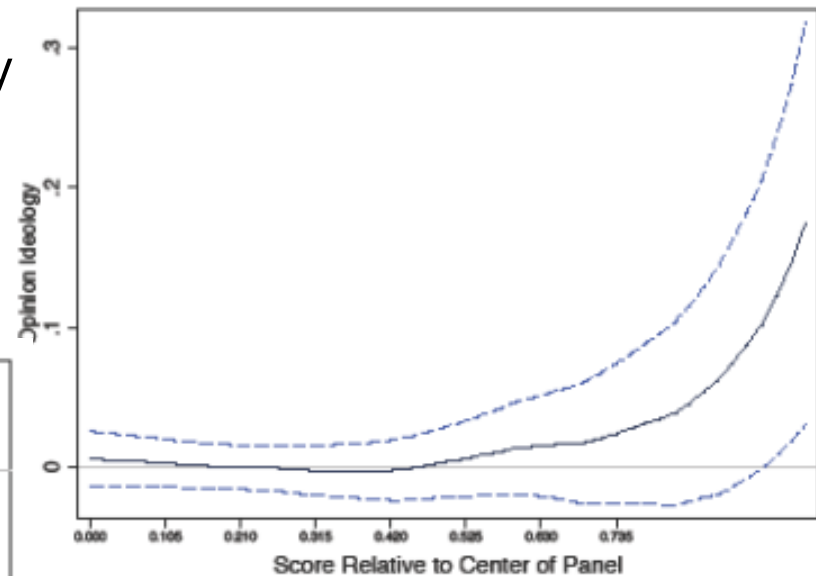

Bins moving from median

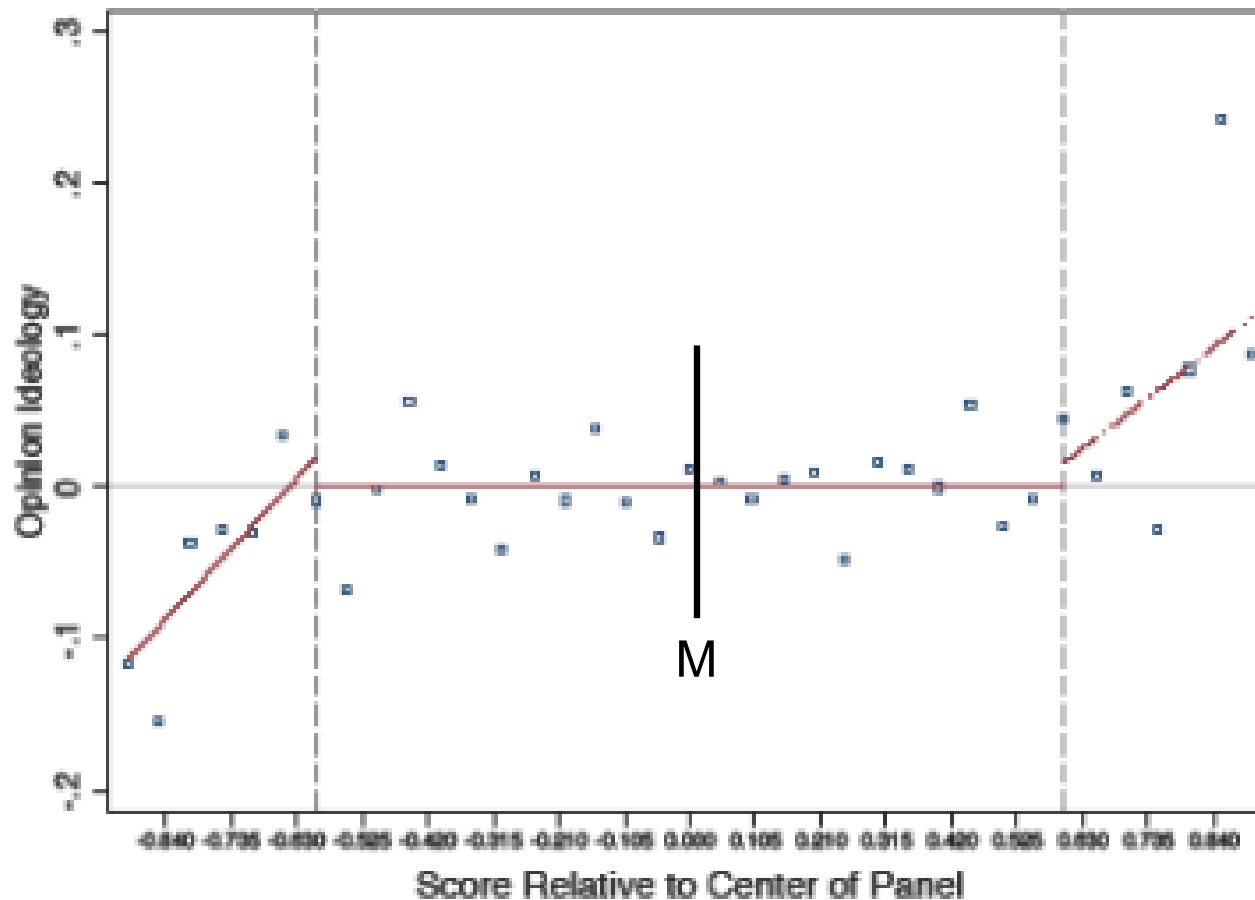

- Structural breaks tests confirm

RESULT: Data consistent with model with intermediate range of ideology.

Conclusions

- Model of group bargaining/voting for policy where agents care about legitimacy of policy.
- Agent will want to endorse good policies but not bad.
- Result: Median wins power to propose.
- Result: Median voter theorem holds in groups where each other agent is either very close or very far from median.
- Result: Median voter theorem does **not** hold if group contains at least one agent at intermediate distance from median.
- Test model in U.S. circuit courts.
- Like model predicts: median has strongest bargaining power.
- Like model predicts: gradually moving another judge from median first has no effect on policy but at intermediate range starts pulling the policy.

Next steps



- Structural estimation
- Another prediction, on dissent

Extra slides



Model prediction using real panels

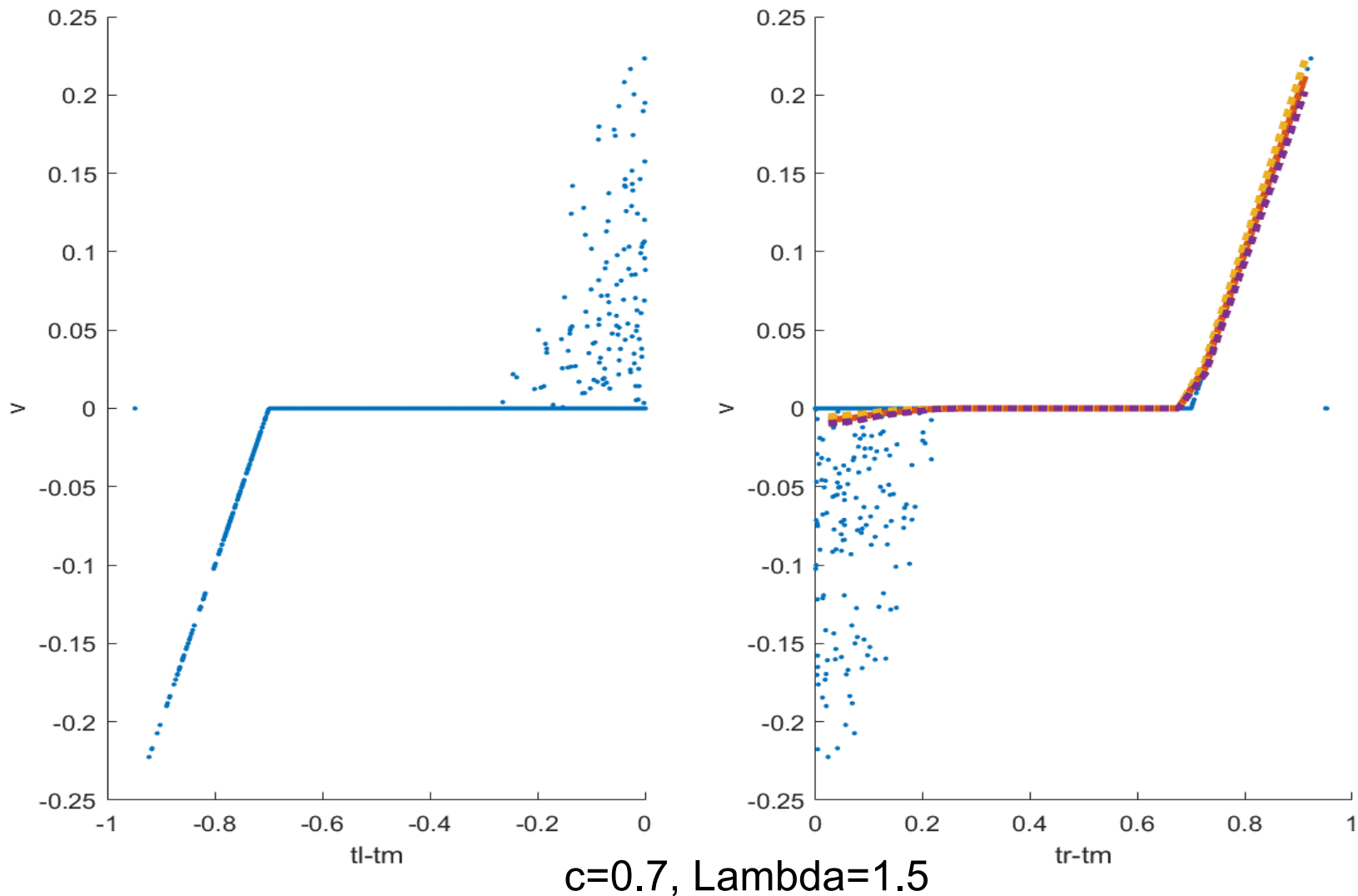

US Circuit Courts

- 12 federal appeals courts
- Each court has a **pool of judges** (8-40).
 - ▣ Once appointed, a judge serves till retirement (80%), death (16%), own resignation (4%).
- For each judicial case, a panel of three judges is **randomly assigned**.
- The panel writes a **majority opinion**, which is the ruling of the court.
- Each individual judge either signs the majority opinion or writes a **minority opinion = dissent** (or concur), which is a costly action:
 - ▣ Psychological cost: being subject to collegial pressure (Epstein et al. 2011)
 - ▣ Time cost: writing it requires time and effort
- **Dissent (or concur) is a form of confrontation**, expressing a disagreement.

US Circuit Courts

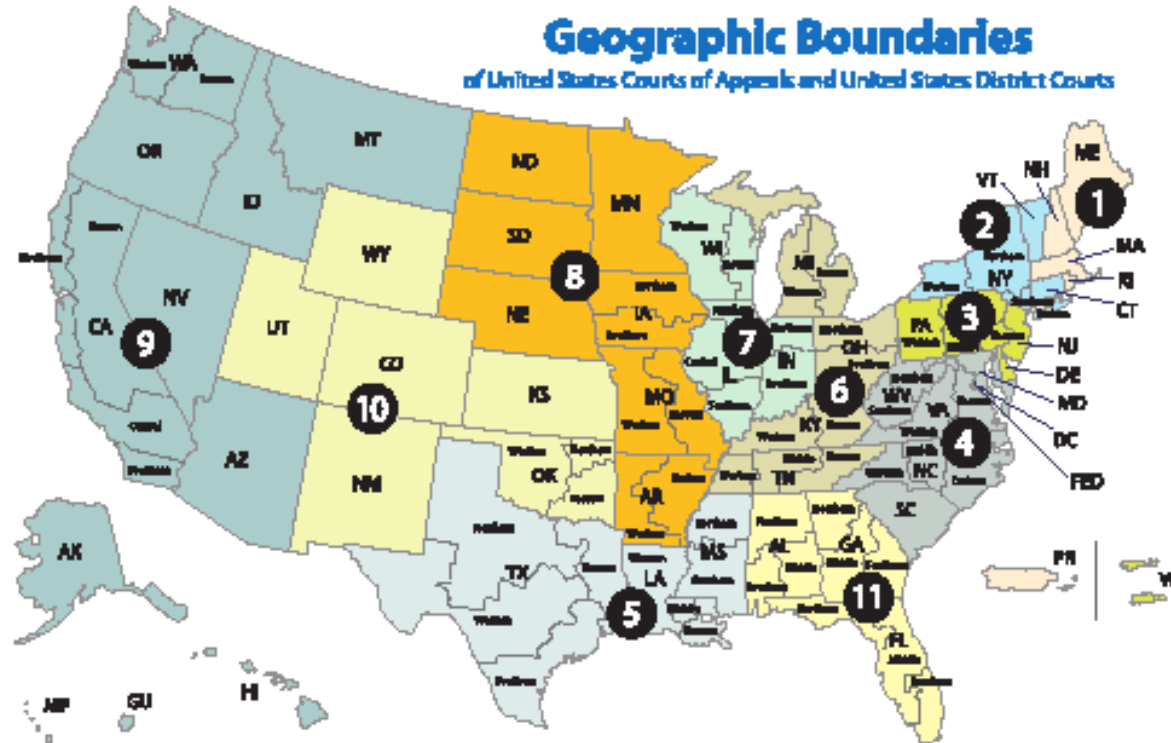

Ideology score, distribution

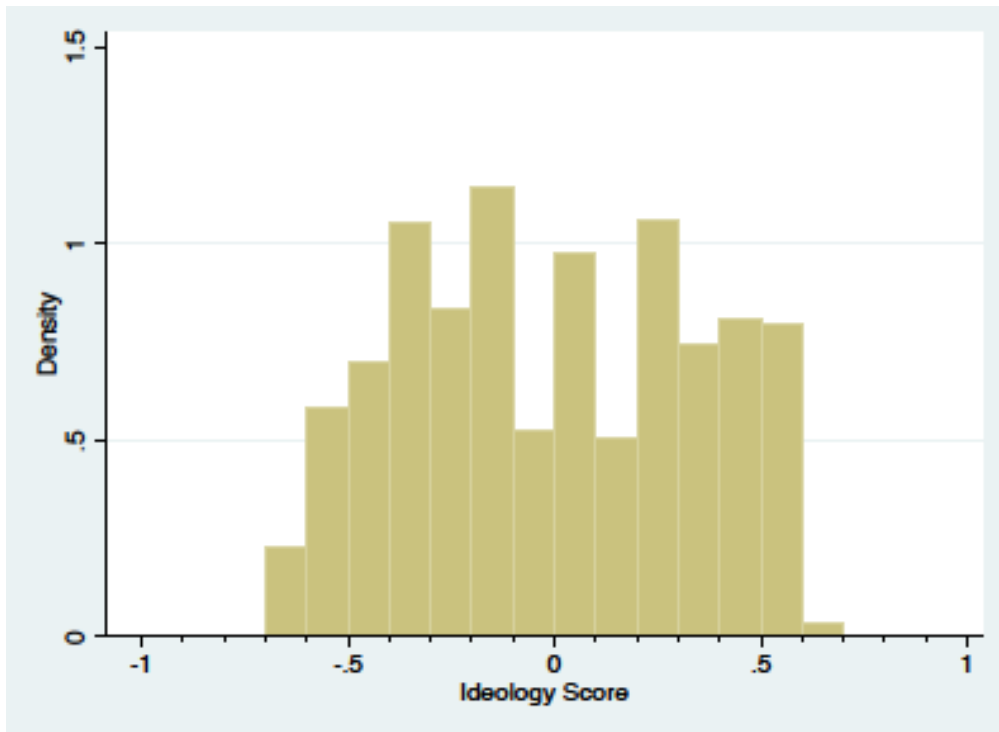

Raw

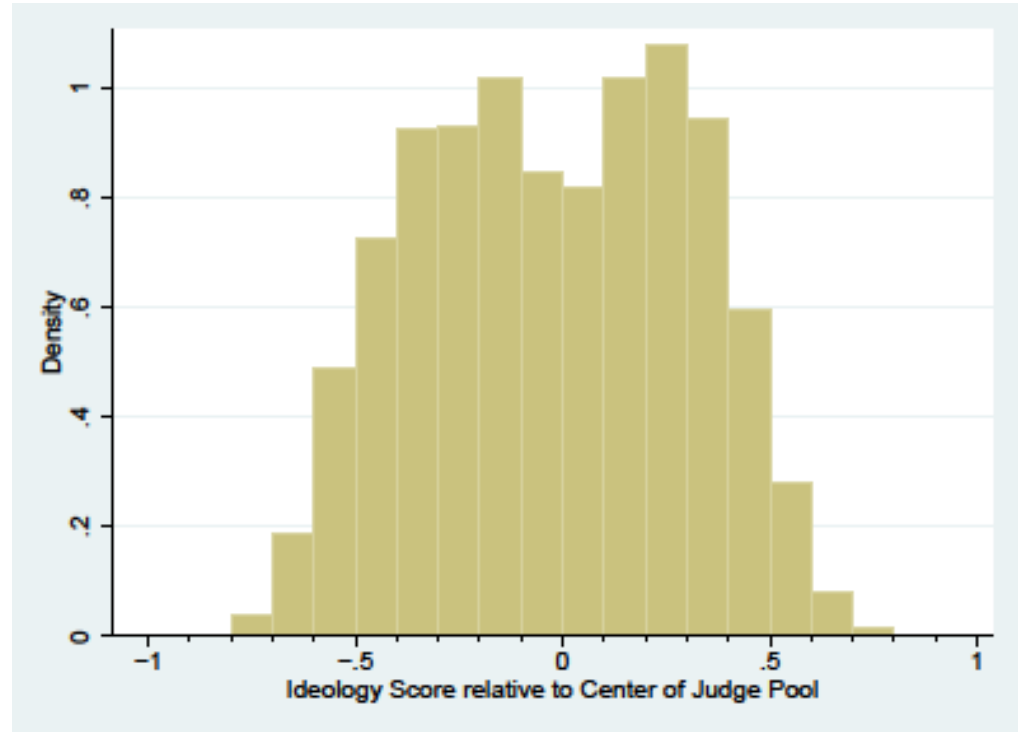

Relative to pool

Performance of “raw” ideology score

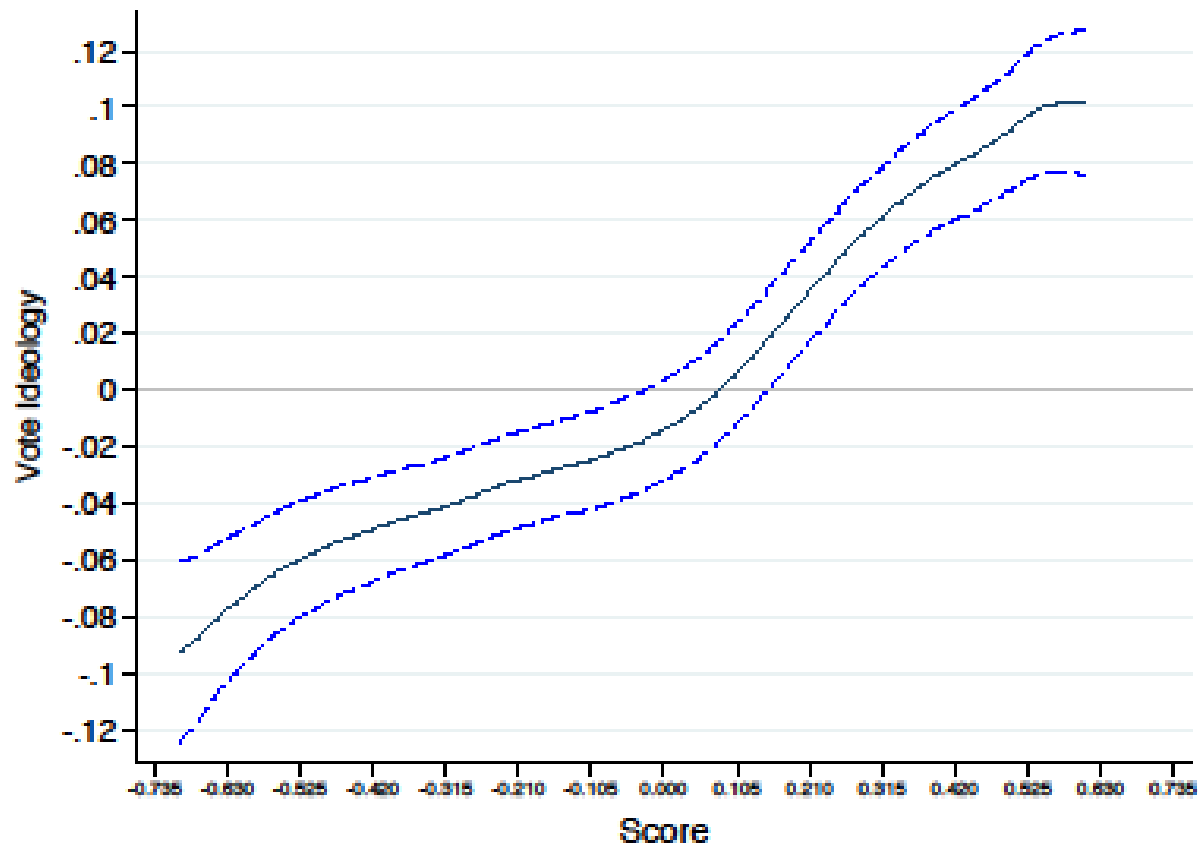

Alternative model

Roughly:

The median-voter theorem holds when either:

- whole group is **cohesive** (both L and R are close to M)
- whole group is **distant** (both are far from M)
- group is **half cohesive half distant** (one is close, the other far from M)

If one (or two) agent is at **intermediate distance**, median-voter theorem does not hold.

